

Lecture 1 — Introduction

Stanford CS343D (Winter 2024)
Fred Kjolstad

Course staff



Fred Kjolstad



AJ Root

Administria

- Syllabus at <https://cs343d.github.io>
- Discussion will happen through Ed in Canvas
- Office Hours
 - Fred: Friday 11-12noon in Gates 486
 - AJ: Wednesday 3-4pm in Gates 4A common area

Goals of the Course

- Introduce you to domain-specific and collection-oriented programming languages from the past
- Introduce you to compiler techniques to get good performance for dense and sparse applications
- Bring you to one of the frontiers of PL and compiler research
- Get you thinking about abstractions and semantics
- “What are the three biggest ideas in computer science? Abstraction, abstraction, abstraction.”
-Paul Hudak

Expectations

- Read papers and engage in class (25%)
 - ~2 readings per class
 - Classes will have a lecture followed by paper discussion
 - Everyone will get a chance to lead a discussion
- Two assignments (20%)
 - MiniAPL
 - Sparse Coiteration Code Generation
- Essay (15%)
- Project (40%)

It is all about performance and productivity

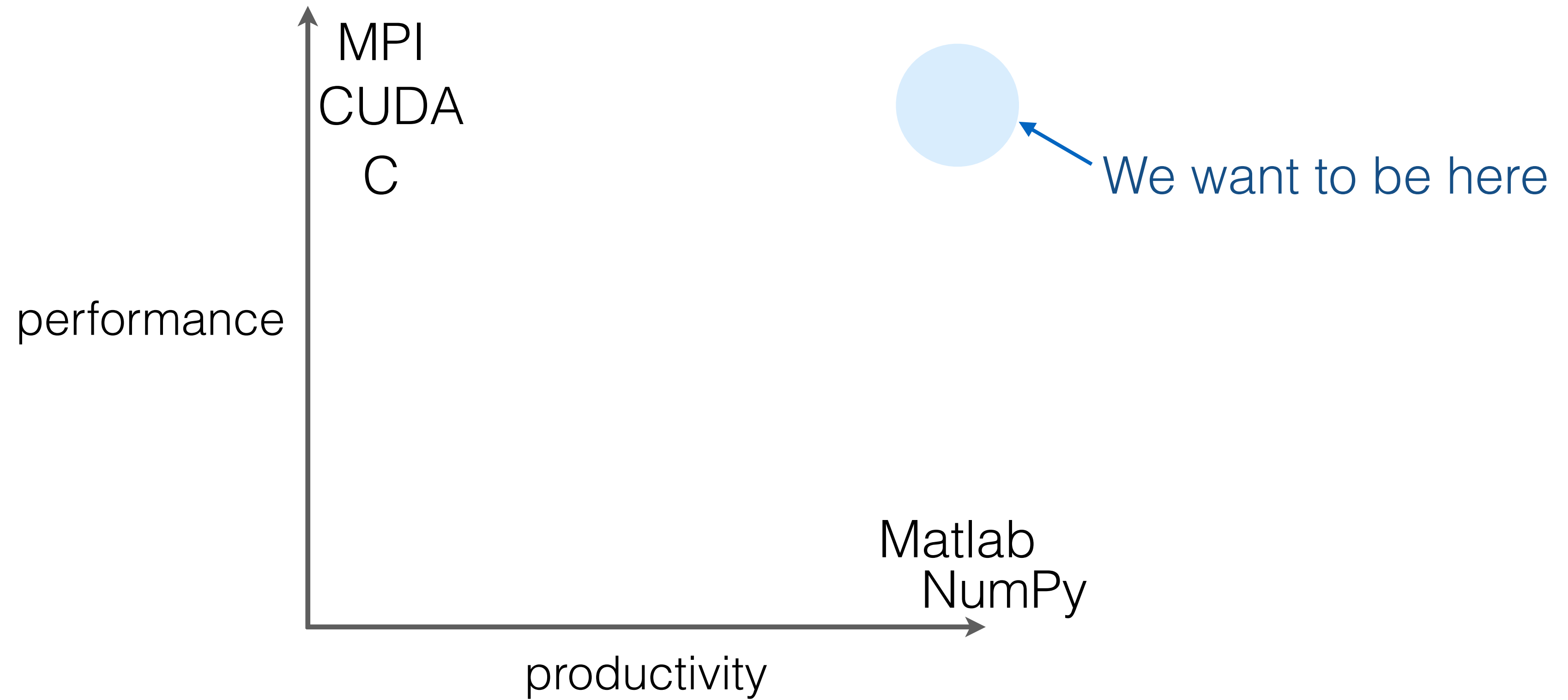

Performance translates to less time and less energy



Data centers



Supercomputers



Self-driving cars

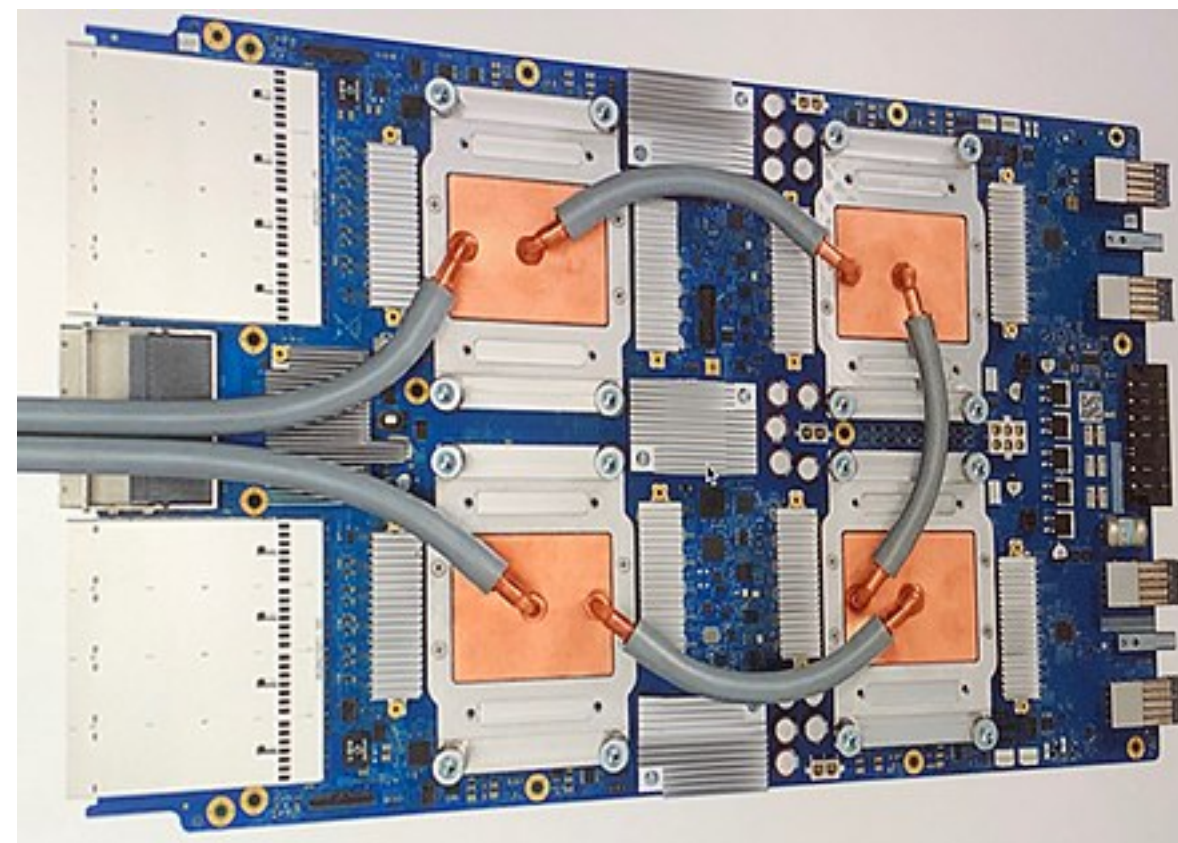

Tensor Processing Unit



Cell-phone batteries

Eras of Computing

Simulation

(1945–1965)

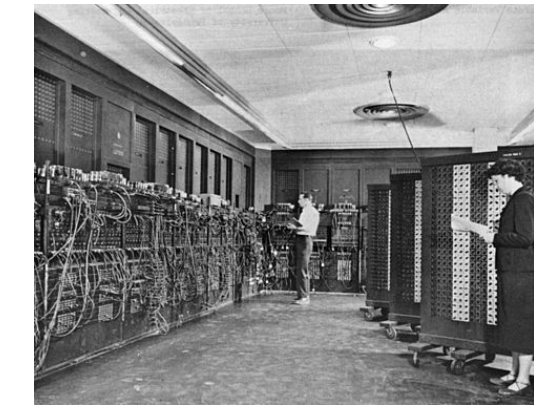

Data processing

(1965–1984)



Personal Computing

(1984–1995)



Communication

(1995–2018)



Interaction



Modern applications are performance hungry

Simulation and Optimization

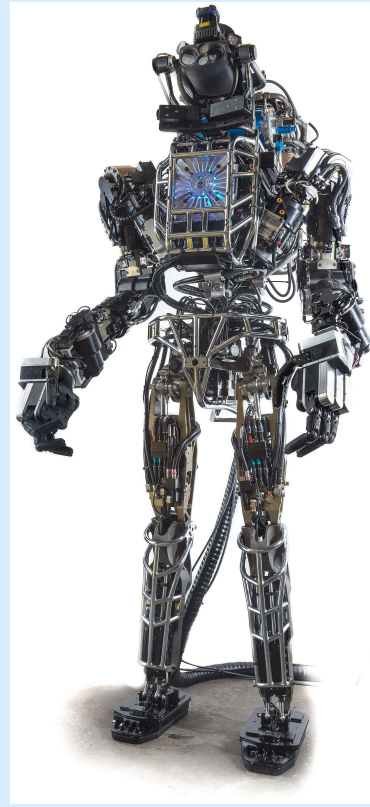

Robotics



Graphics Simulations

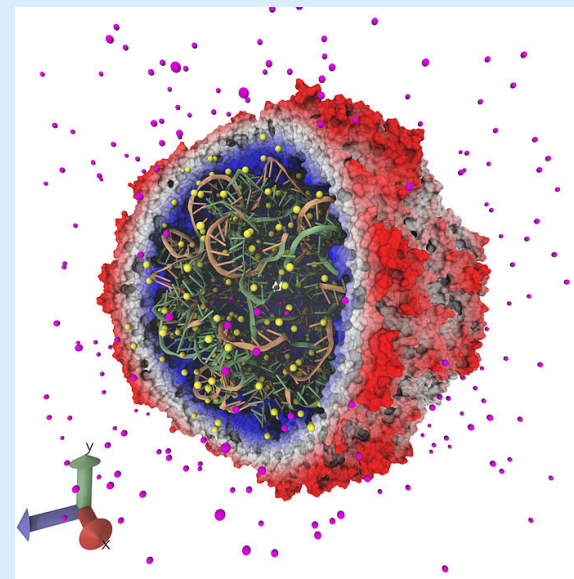

Virus Modelling

Data Analytics



Social Networks

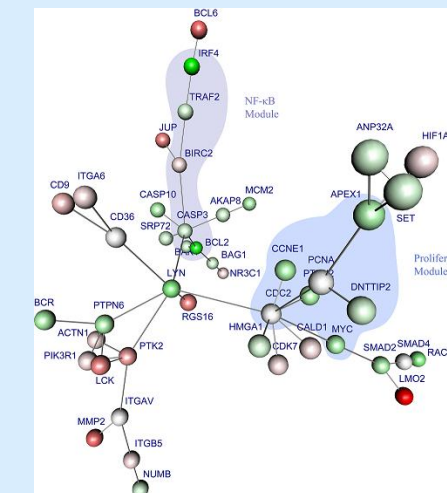

Computational Biology

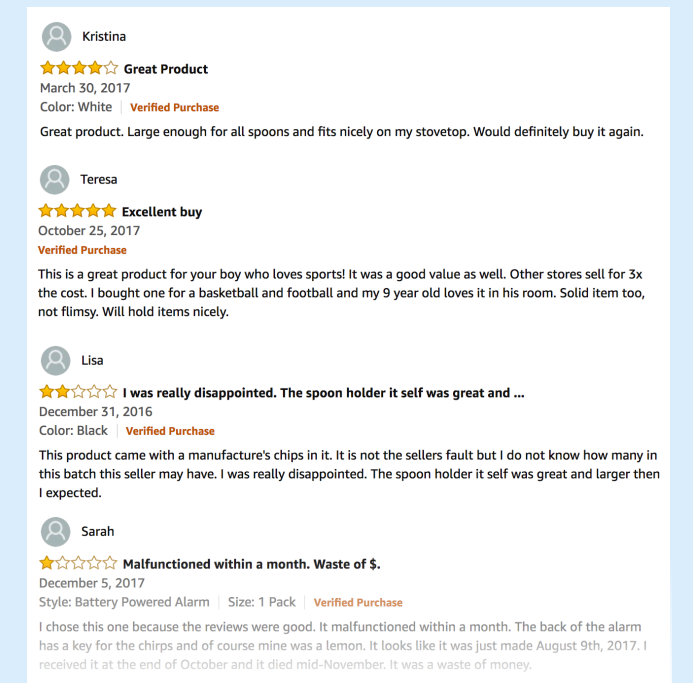

Recommender Systems



Machine Learning

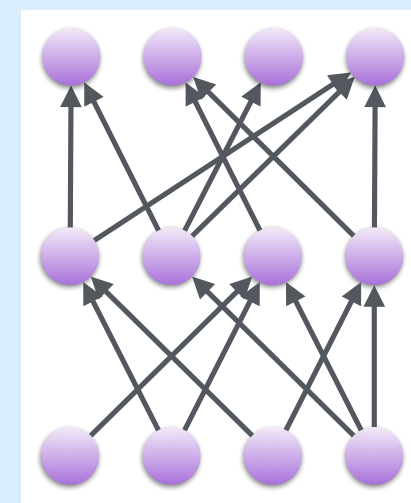

Neural Networks

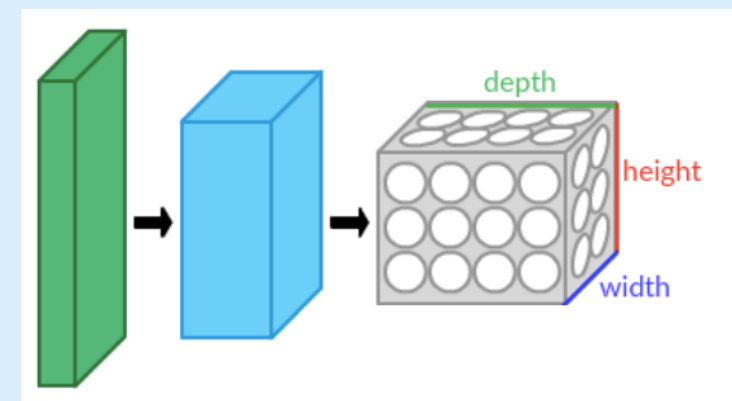

Convolutional Networks

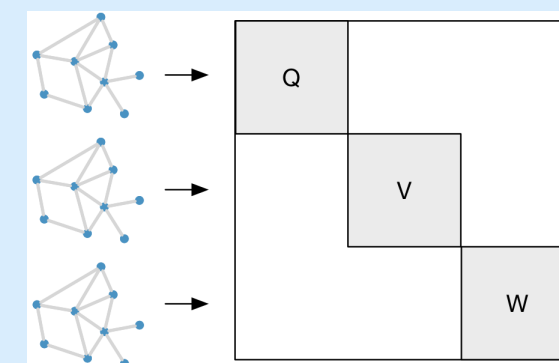

Graph Convolutional Network

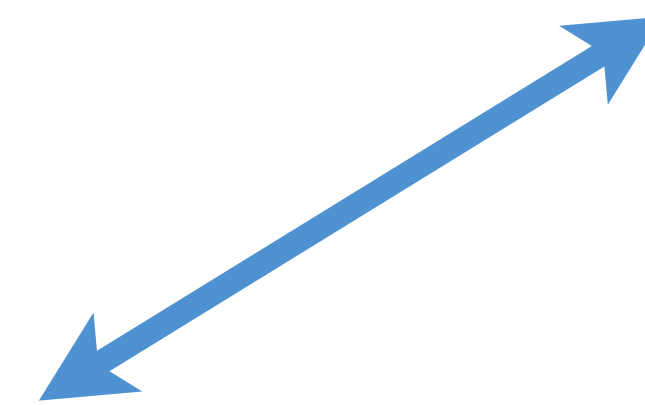
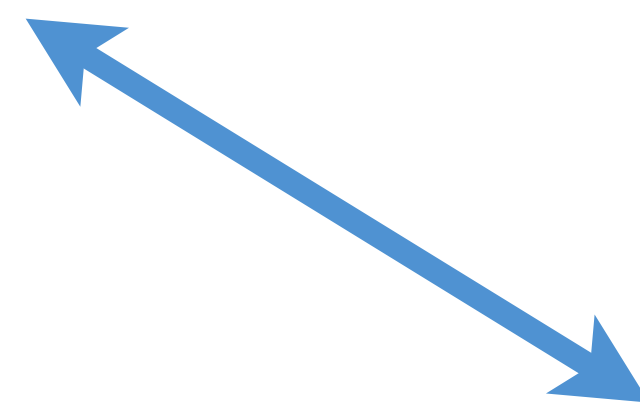

Modern hardware is heterogeneous and programming it is hard

5th Gen Intel® Core™ Processor Die Map 14nm 2nd Generation Tri-Gate 3-D Transistors

5th Gen Intel® Core™ Processor
with Intel® HD Graphics 6000 or
Intel® Iris™ Graphics 6100

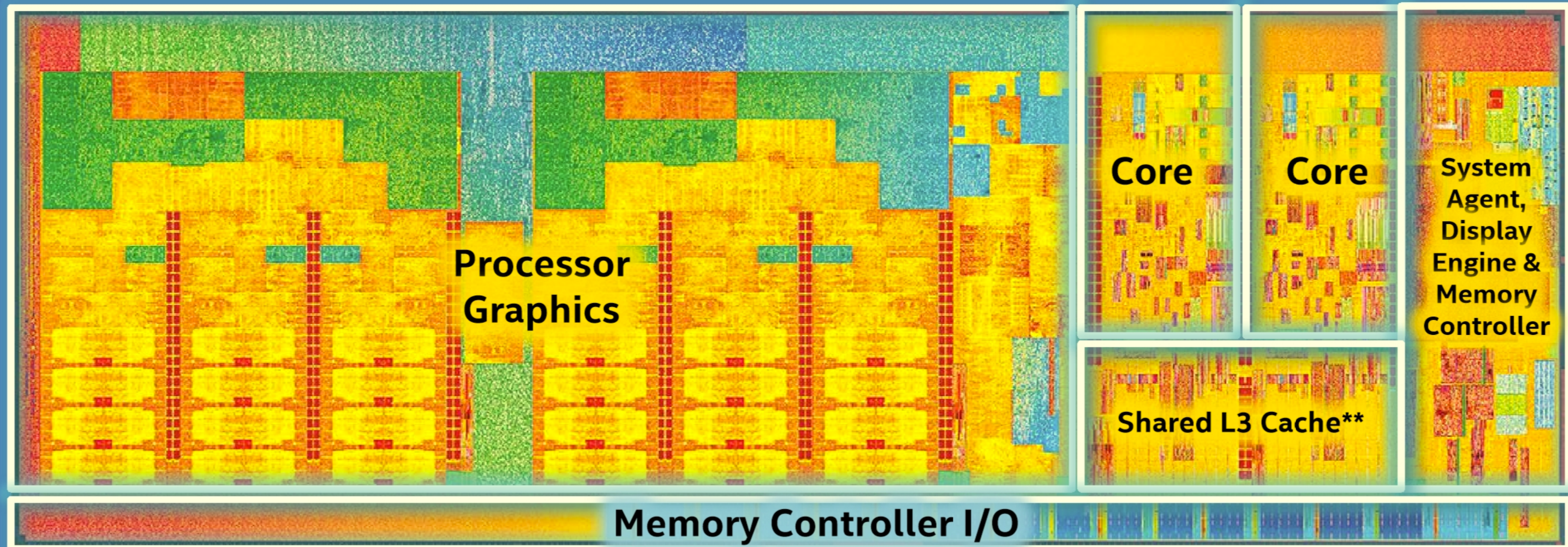

Dual Core Die Shown Above

Transistor Count: 1.9 Billion

Die Size: 133 mm²

4th Gen Core Processor (U series): 1.3B

4th Gen Core Processor (U series): 181mm²

** Cache is shared across both cores and processor graphics



Hardware in the Clouds

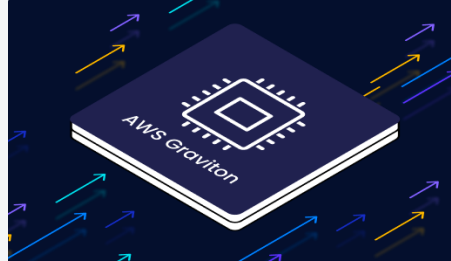
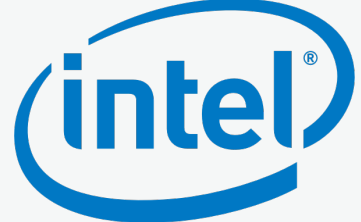

aws

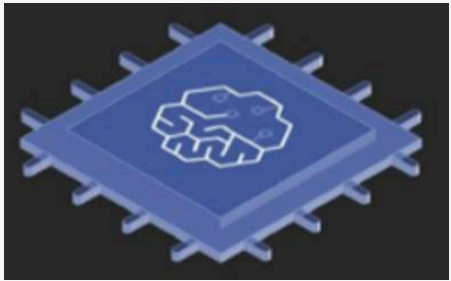

Graviton





Inferentia



Trainium



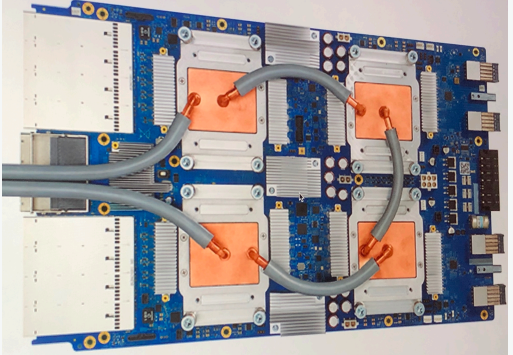

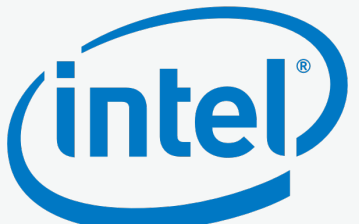
Google Cloud



TPU



Microsoft Azure

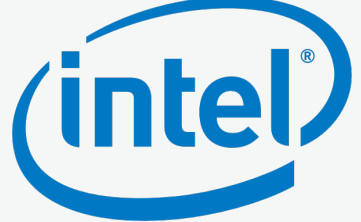

FPGAs



A lot of industry activity

AI Chip Landscape

V0.7 Dec., 2019

S.T.

MLPerf results available AI-Benchmark results available



All information contained within this infographic is gathered from the internet and periodically updated, no guarantee is given that the information provided is correct, complete, and up-to-date.

The Road to Point Reyes Lucasfilm 1984

R.E.Y.E.S = Renders Everything You Ever Saw



```
surface corrode(float Ks=0.4, Ka=0.1, rough=0.25) {  
    float i, freq=1, turb=0;  
    // compute fractal texture  
    for( i=0; i<6; i++ ) {  
        turb+=1/freq*noise(freq*P);  
        freq*=2;  
    }  
    // perturb surface  
    P -= turb * normalize(N);  
    N = faceforward(normalize(calculatenormal(P)));  
    // compute reflection and final color  
    Ci = Cs*(Ka*ambient()+Ks*specular(N,I,rough));  
}
```

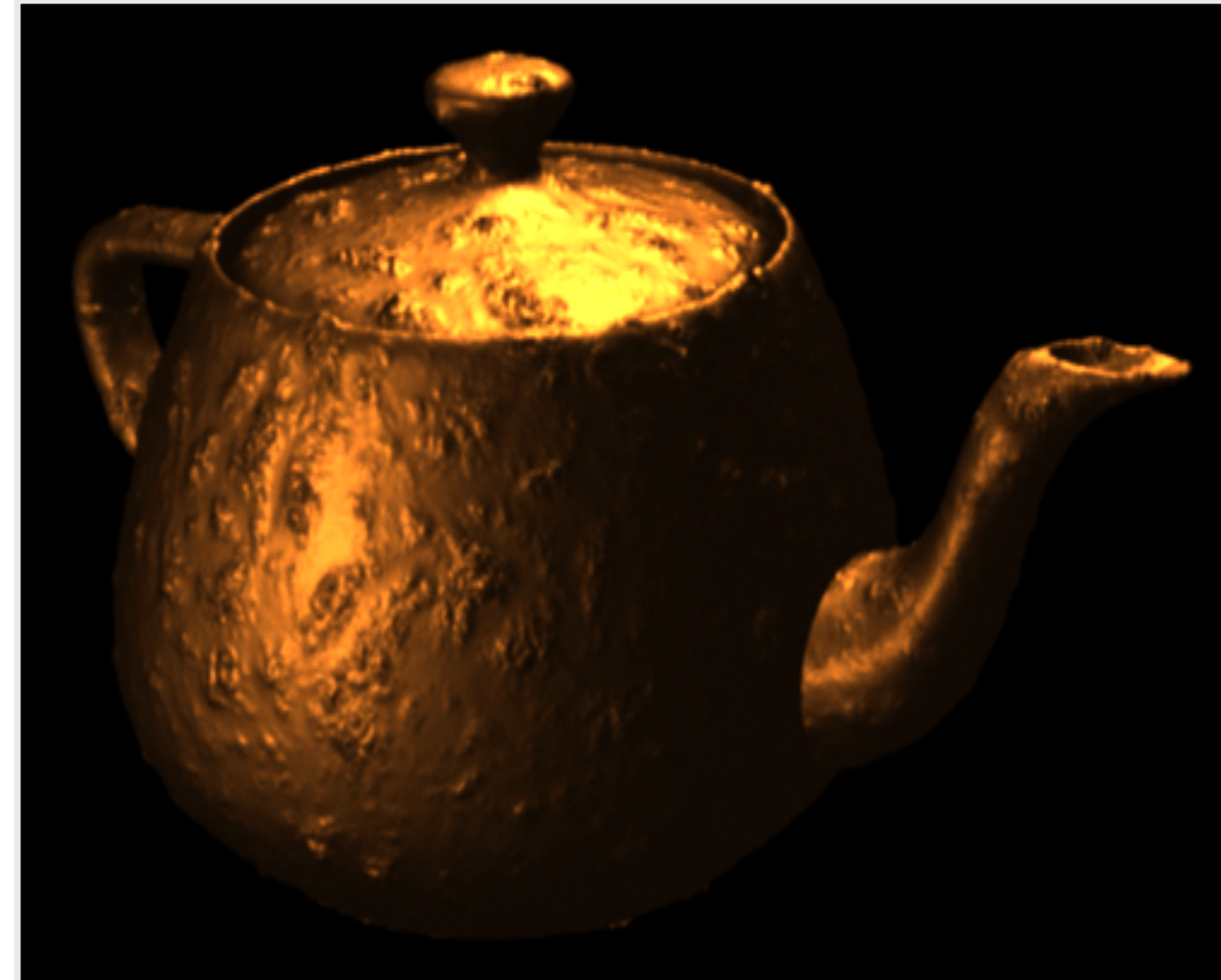

Little Languages (DSLs)

Jon Bentley, CACM 29(8), 1986

Defining “little” is harder; it might imply that the first-time user can use this system in an hour or master the language in a day, or perhaps the first implementation took just a few days. In any case, a little language is specialized to a particular problem domain and does not include many features found in conventional languages.

UNIX "DSLs"

bash, csh - shell programming

awk - processing strings

sed - regular expressions

troff, pic, tbl, eqn, ...

printf formatting

...

Programming Languages

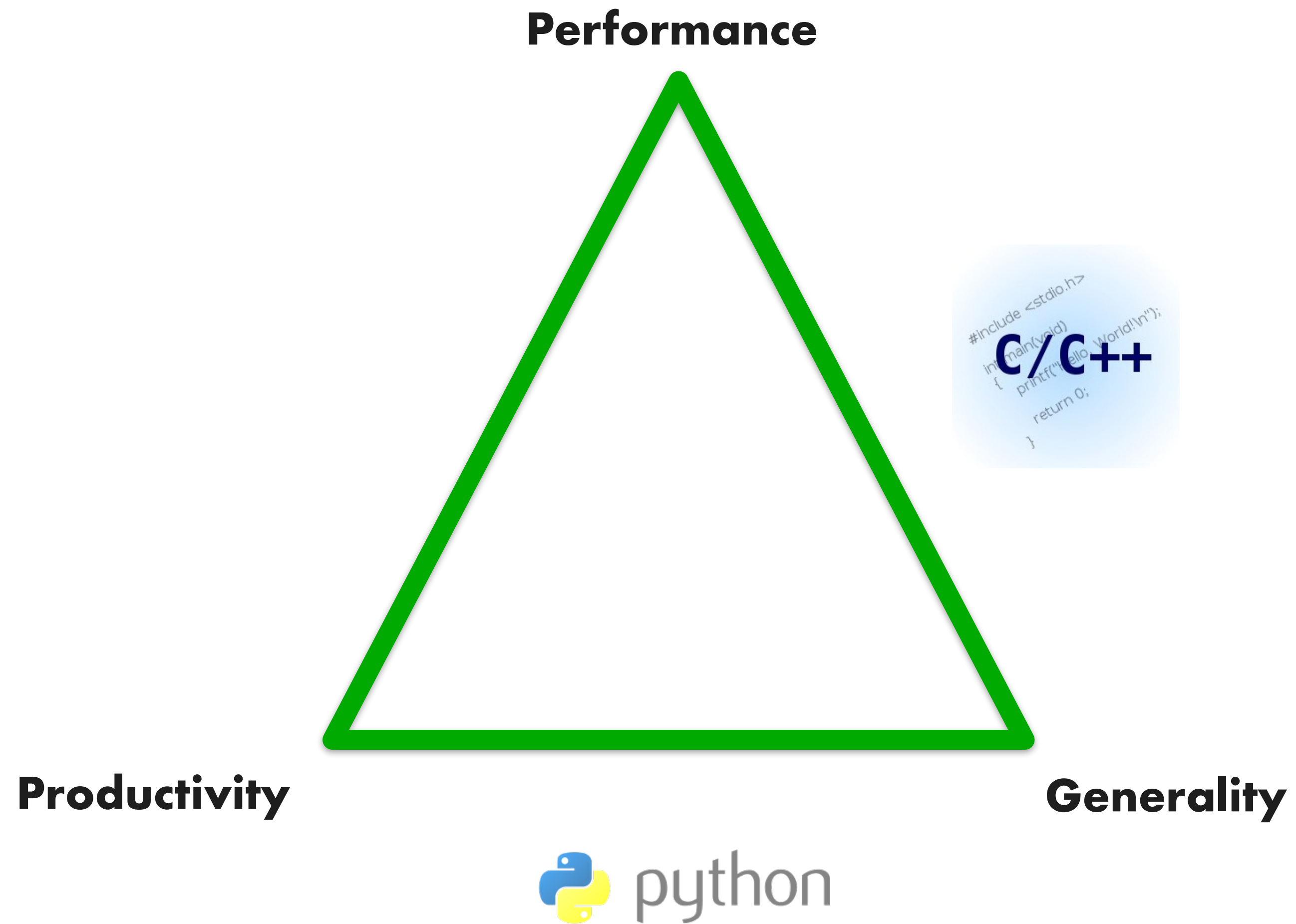

Domain-Specific Languages

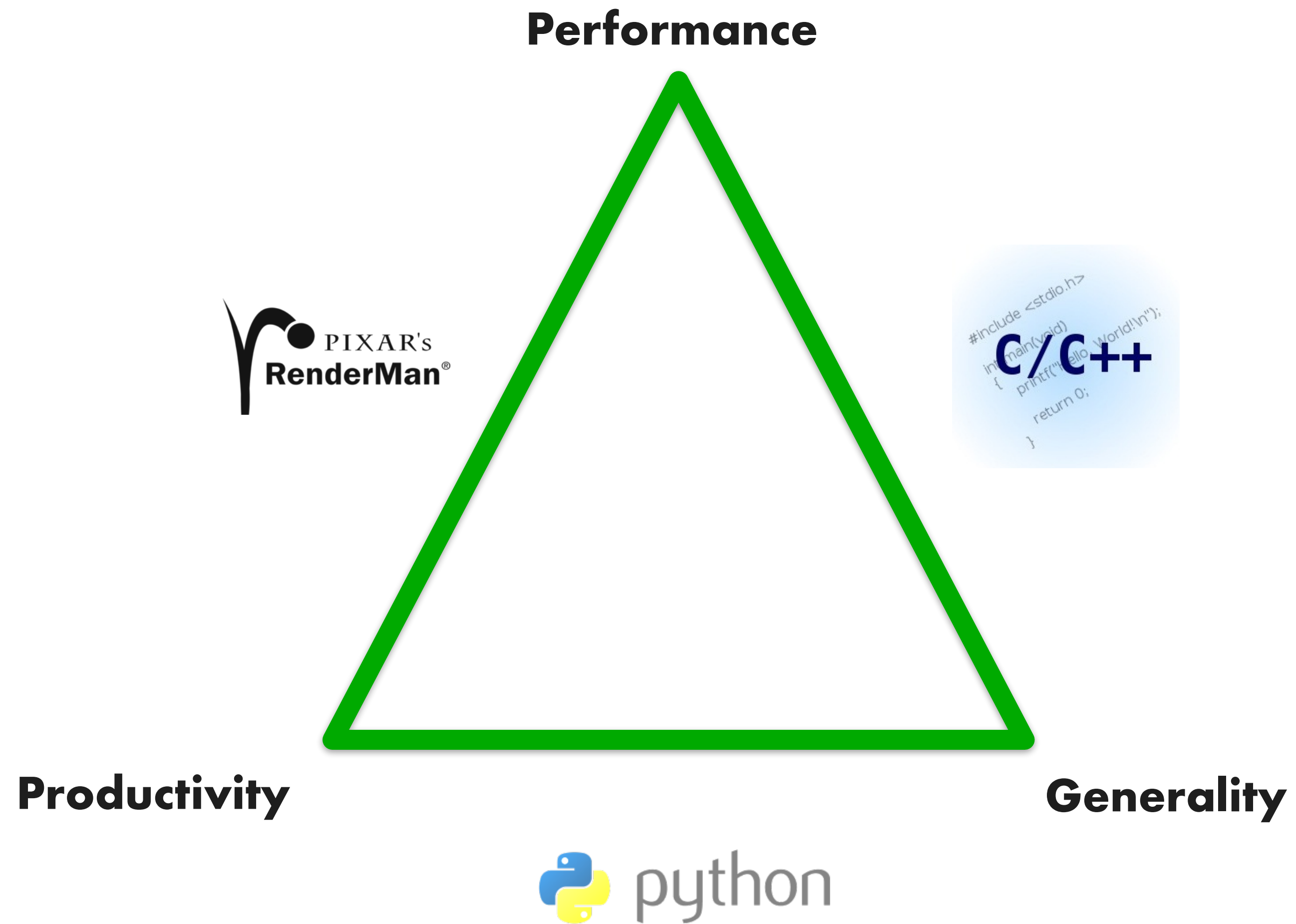

Graphics Libraries

```
glPerspective(45.0);  
for( ... ) {  
    glTranslate(1.0, 2.0, 3.0);  
    glBegin(GL_TRIANGLES);  
        glVertex(...);  
        glVertex(...);  
        ...  
    glEnd();  
}  
glSwapBuffers();
```

OpenGL “Grammar”

<Scene> = <BeginFrame> <Camera> <World>
<EndFrame>

<Camera> = glMatrixMode(GL_PROJECTION)

<View>

<View> = glPerspective | glOrtho

<World> = <Objects>*

<Object> = <Transforms>* <Geometry>

<Transforms> = glTranslatef | glRotatef | ...

<Geometry> = glBegin <Vertices> glEnd

<Vertices> = [glColor] [glNormal] glVertex

Advantages

Productivity

- Graphics library is easy to use

Portability

- Runs on wide range of GPUs

Performance

- Runs in parallel

Restrictions

- Vertices/Fragments are independent
- Rasterization can be done in hardware
- Textures are read-only; texture filtering hw
- Specialized scheduler for pipeline
- ...
- Allows for super-optimized implementations

**Abstraction is about
restrictions,
in order to get
useful properties**

Advantages

Productivity

Portability

Performance

Encourage innovation

- Allows vendors to radically optimize hardware architecture to achieve efficiency
- Allows vendors to introduce new low-level programming models and abstractions

Domain-Specific Languages

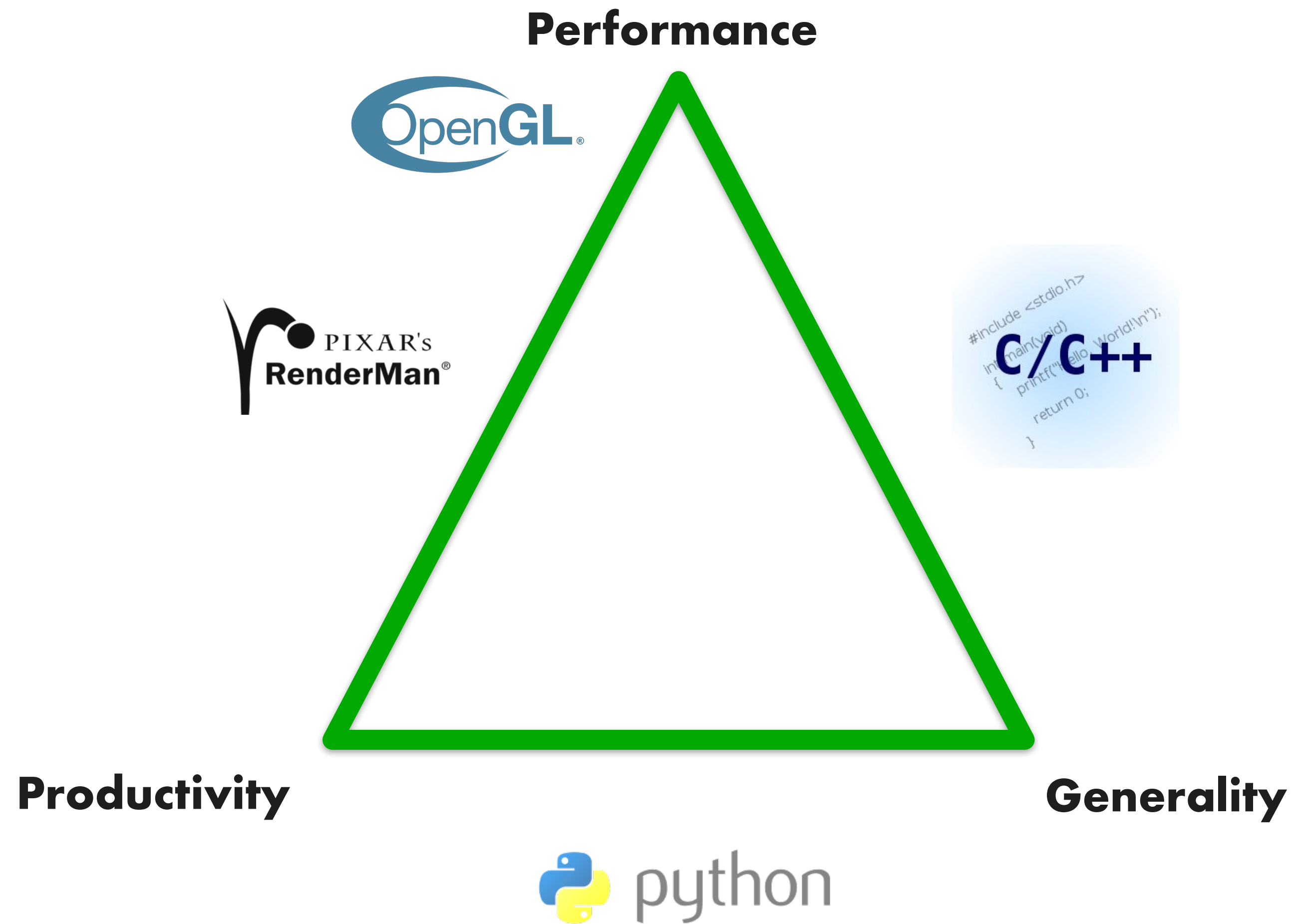

Definition: Domain-Specific

Definition: A language or library that exploits domain knowledge for productivity and performance

Widely used in many application areas

- matlab / R
- SQL / map-reduce / Microsoft's LINQ
- TensorFlow, pytorch

Domain-Specific Languages

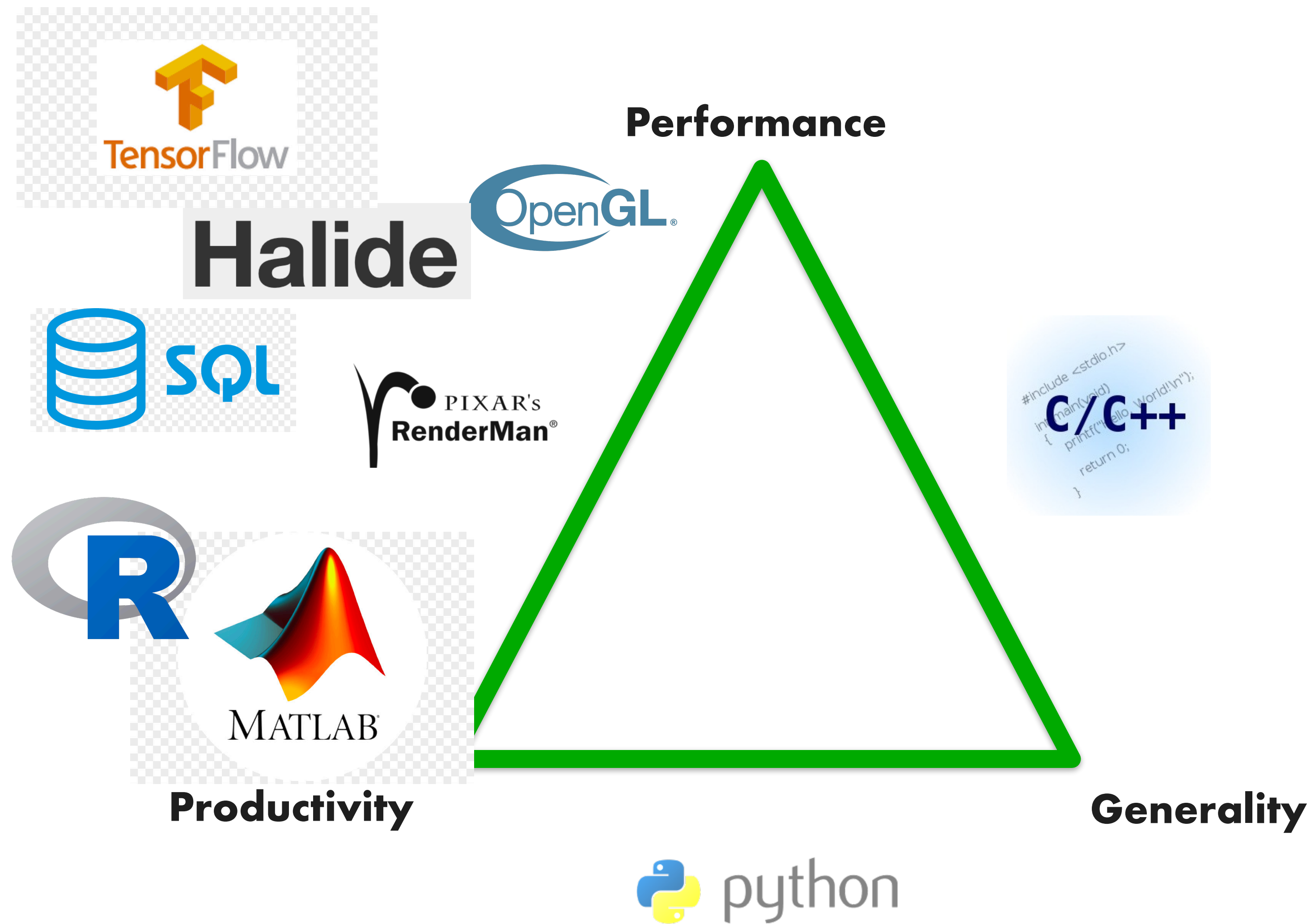

Why DSLs Work

Advantages

- Add the semantics of the domain
 - High-level program transformations
- Restrict programming language
 - Less-general computations
 - Guarantee static analysis
- Known parallelization strategies
 - Someone has shown how to robustly do it

=> Tractable

Moore's Law – The number of transistors on integrated circuit chips (1971-2016)

Moore's law describes the empirical regularity that the number of transistors on integrated circuits doubles approximately every two years. This advancement is important as other aspects of technological progress – such as processing speed or the price of electronic products – are strongly linked to Moore's law.

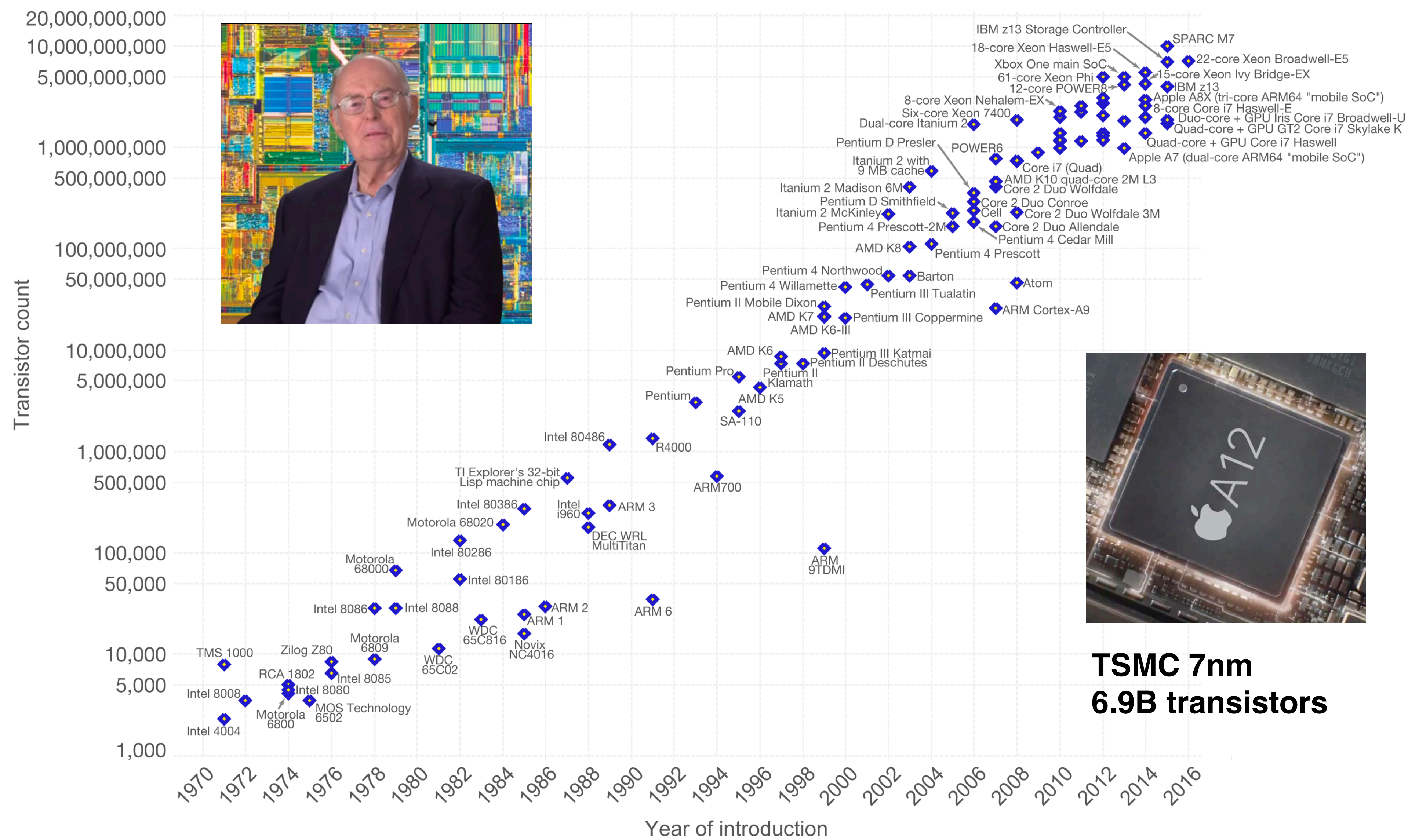

Data source: Wikipedia (https://en.wikipedia.org/wiki/Transistor_count)
The data visualization is available at [OurWorldinData.org](https://www.ourworldindata.org). There you find more visualizations and research on this topic.

Licensed under [CC-BY-SA](https://creativecommons.org/licenses/by-sa/4.0/) by the author Max Roser.

A New Golden Age for Computer Architecture: Domain-Specific Hardware/Software Co-Design

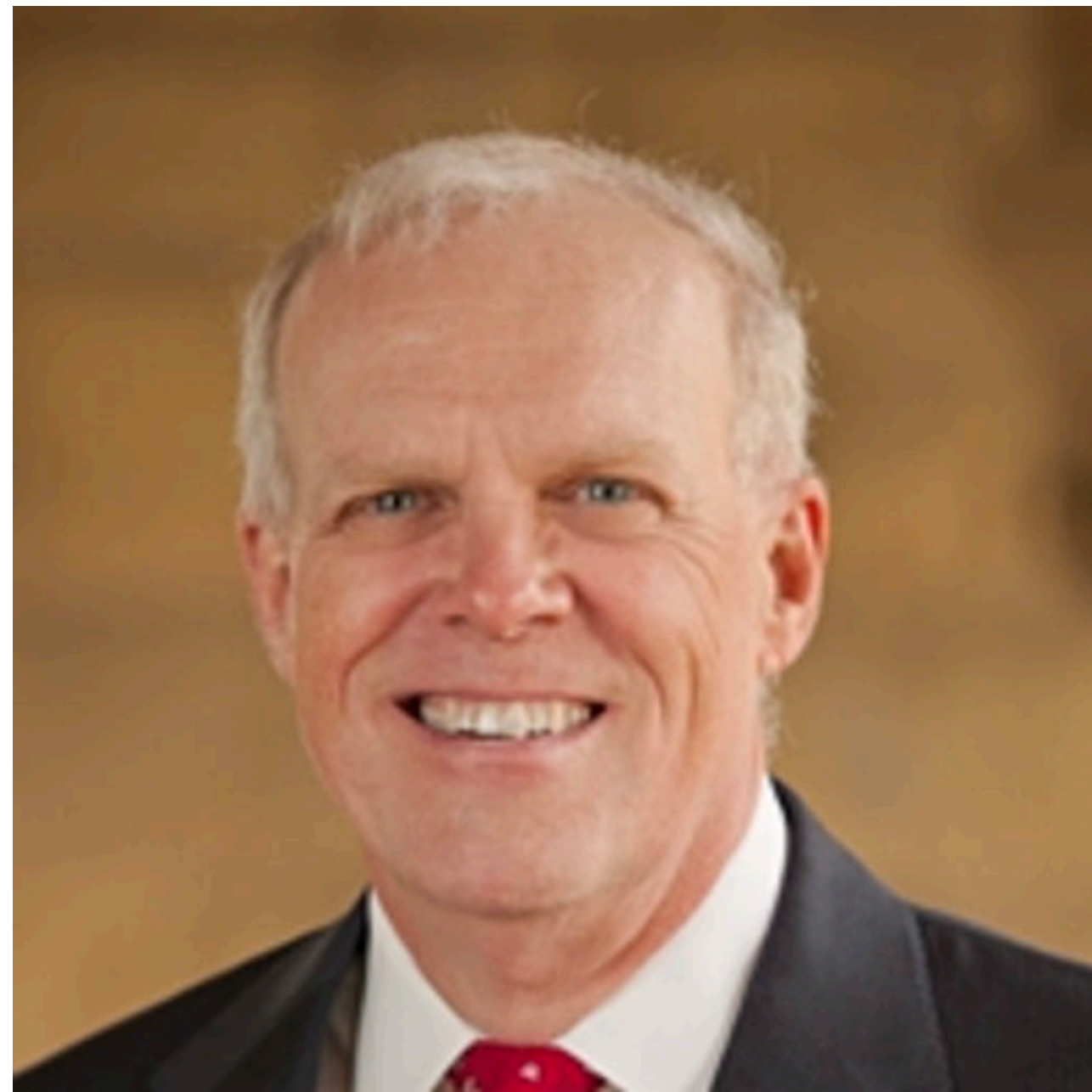

John Hennessy



David Patterson

2017 Turing Award

Large efficiency gains with domain-specific architectures

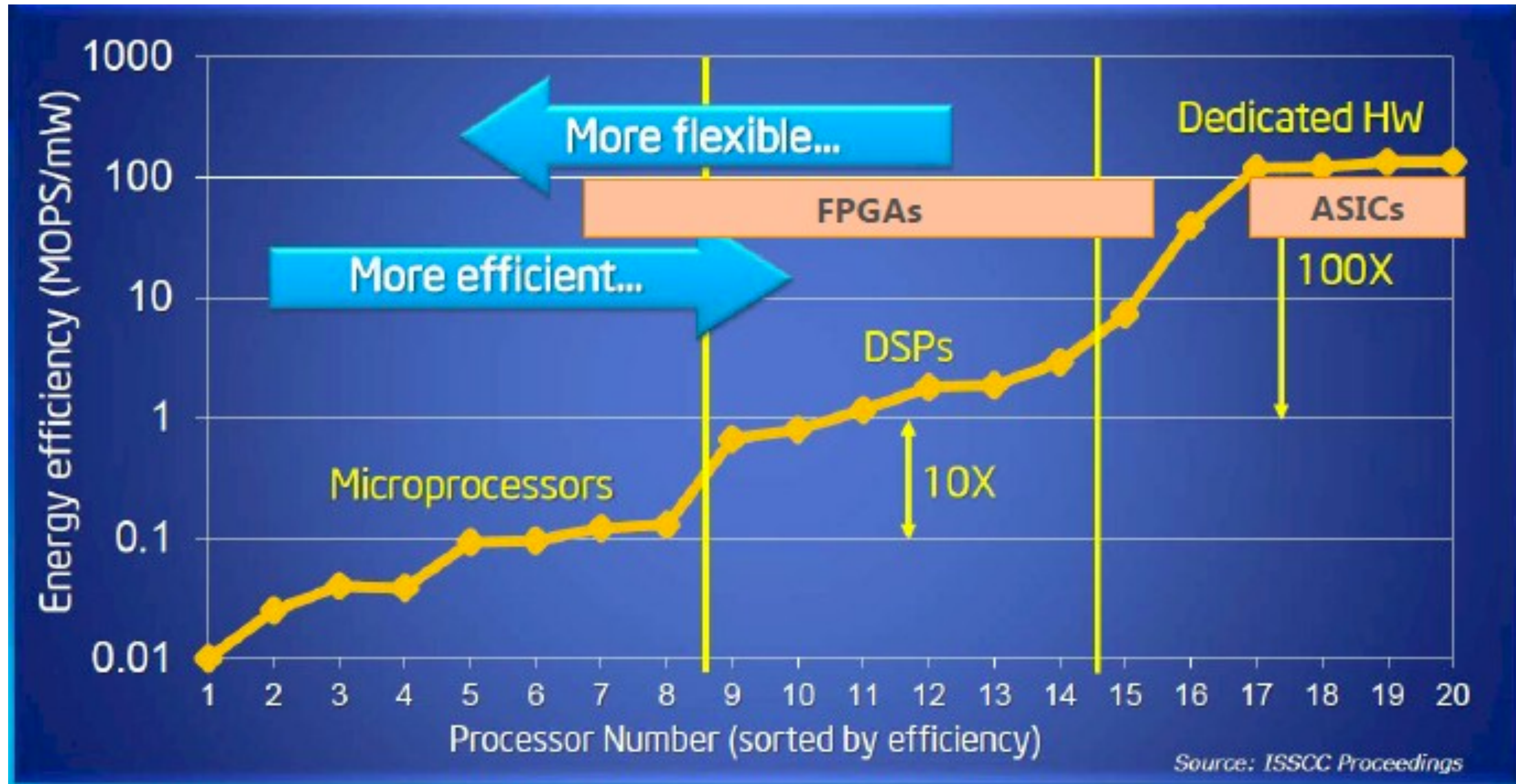

Source: Bob Broderson, Berkeley Wireless group

Domain-Specific Architectures

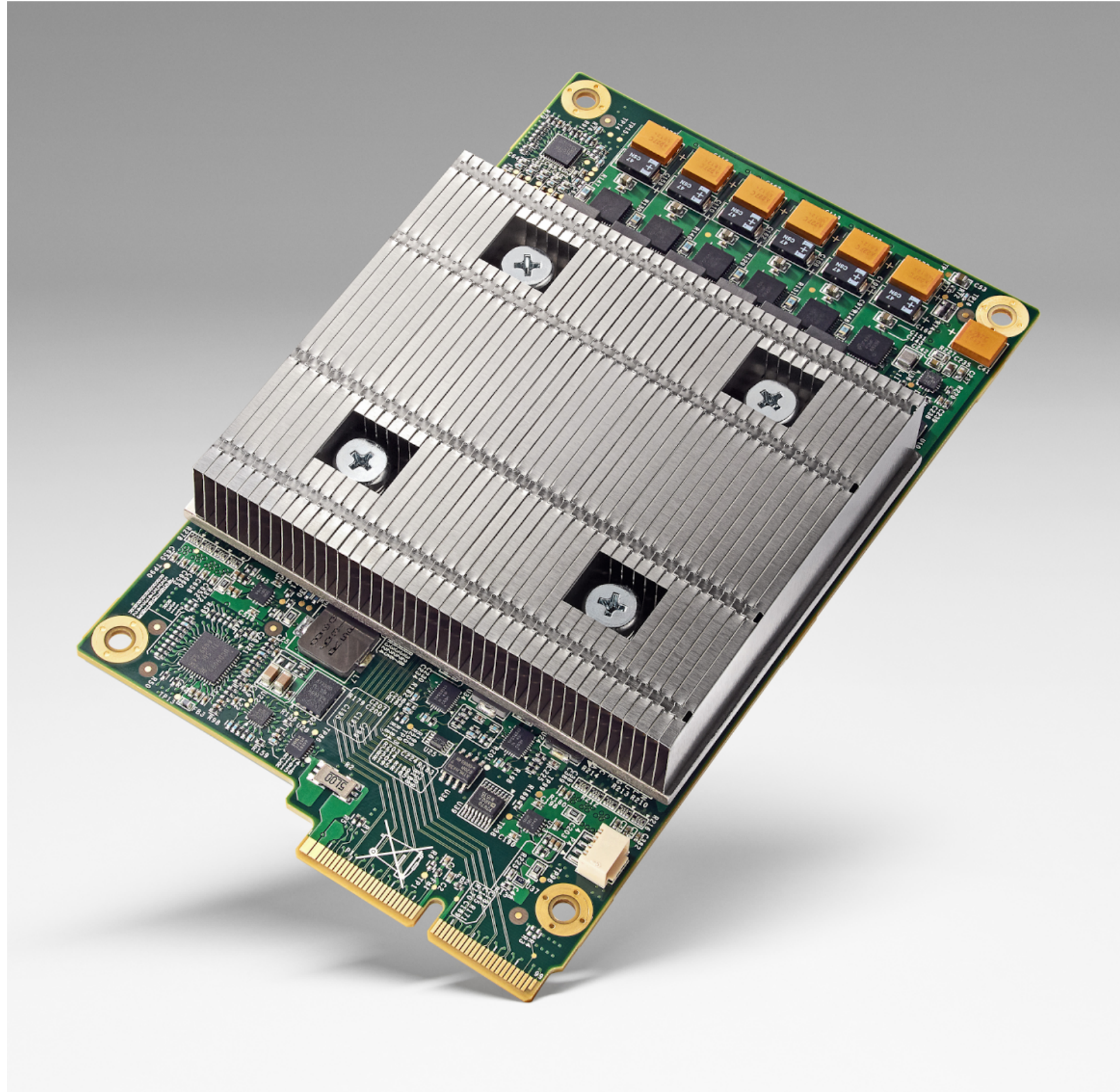

**Google
Tensor Processing Unit**

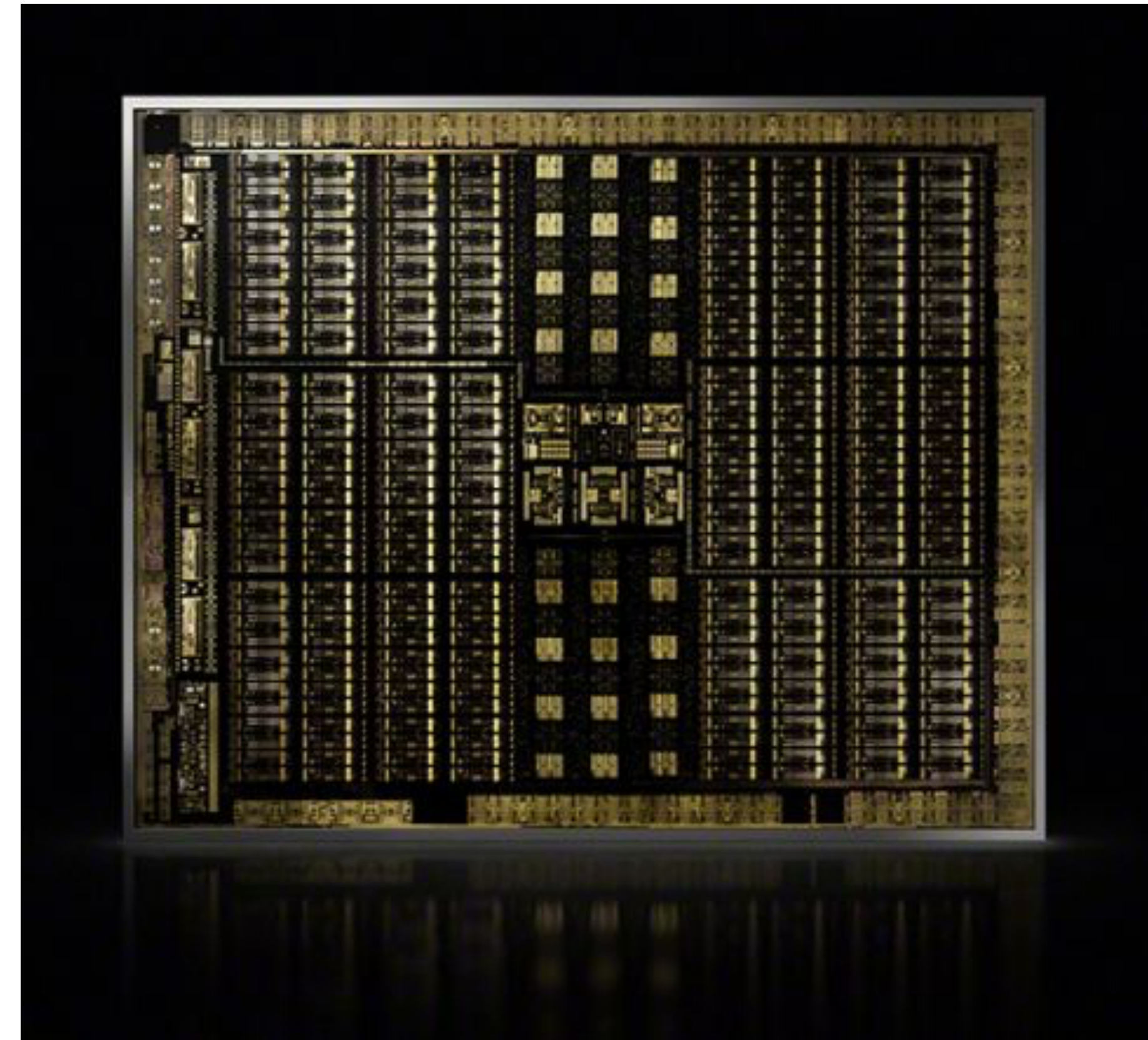

**NVIDIA
Turing Architecture**

Collection-Oriented Languages

Lists

Lisp M58



Sets

SETL S70



Nested Sequences

NESL B94

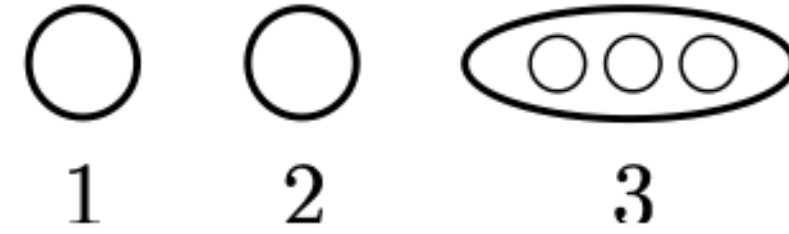

Grids

Sejts S09, Halide

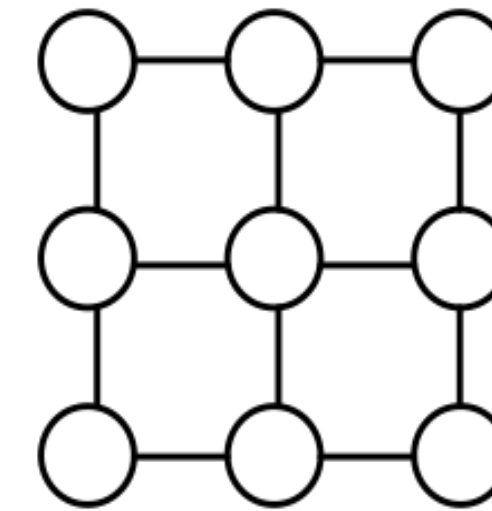

Arrays

APL I62

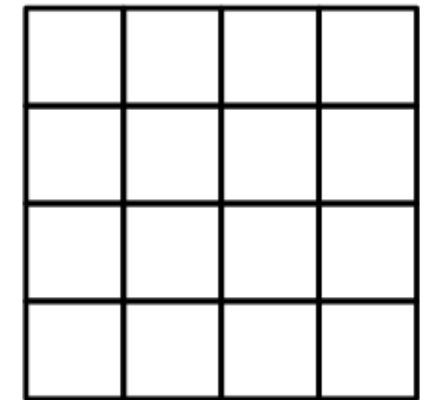

Relations

Relational Algebra C70,

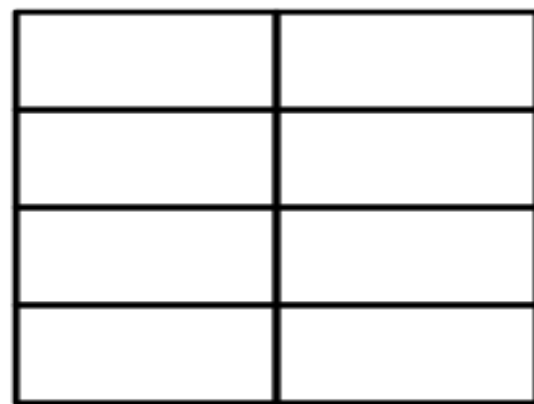

Graphs

GraphLab L10

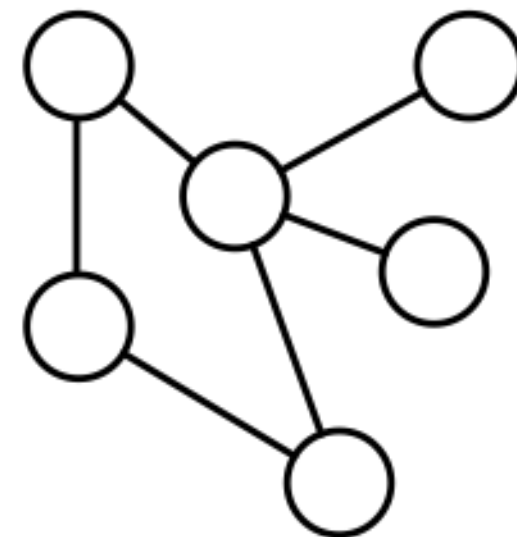

Meshes

Liszt D11



Vectors

Vector Model B90

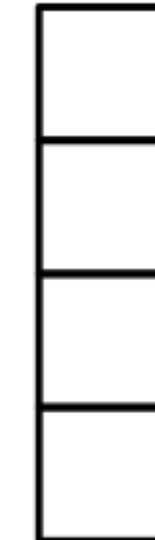

Matrices and Tensors

Matlab M79, taco K17

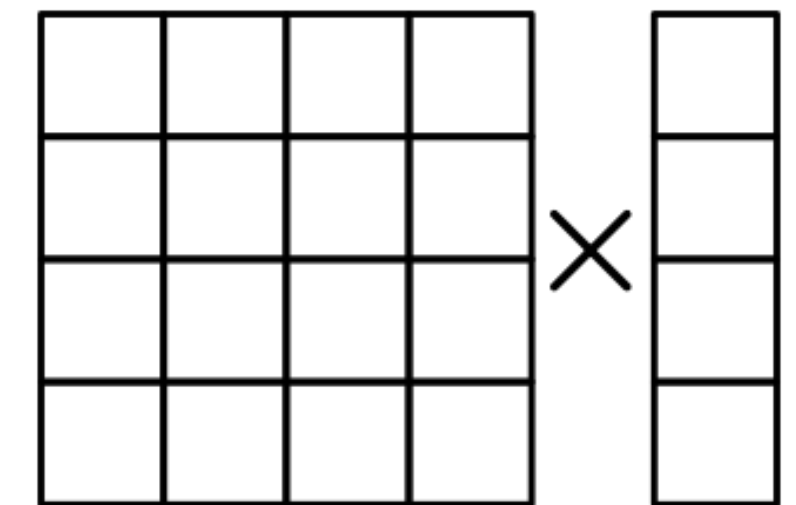

A collection-oriented programming model provides collective operations on some collection/abstract data structure

Modern Domain-Specific Languages/Compilers

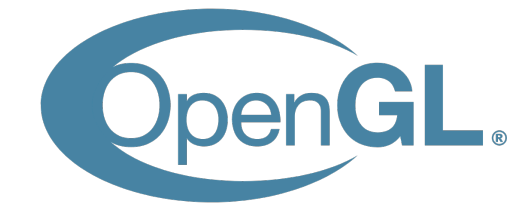

Halide



